

# *Instruction Manual*

## **ZEDA** **BEARTOOTH** **ELECTRIC BIKE**

*500W / 48V - 20" All-Terrain Bicycle*



# ***TABLE OF CONTENTS***

General Information .....	Page 3
Tools Required.....	Page 4
Before You Ride.....	Page 5
LCD Display Overview.....	Page 6
LCD Display Operation.....	Page 7-9
Battery Care and Information.....	Page 10-11
Electric Bike Motor.....	Page 12
Electric Bike Instructions.....	Page 13-20
Safety Checklist.....	Page 21-22
Final Check.....	Page 23
Routine Maintenance.....	Page 23-27
Troubleshooting.....	Page 28-30

# General Information



**FULLY CHARGE BATTERIES BEFORE FIRST USE** - Batteries should be fully charged immediately when they are received and immediately after each use for the recommended charge times.

Li-Ion (Lithium Ion) batteries 4-6 hours

We recommend that you consult an electric bike specialist if you have doubts or concerns regarding your experience or ability to properly assemble, repair, or maintain your electric bike.

Additional warnings are throughout this manual.

With proper care and maintenance your electric bike can be a reliable source of transportation, and a fun form of activity for years to come. Below are some important points that will help you to maximize your enjoyment of your new electric bike. Please read through the entire manual before you attempt to assemble and use your new electric bike.

## FACTORS TO MAXIMIZE THE RANGE OF YOUR ELECTRIC BIKE

### ⇒ Rider Input

The more the rider pedals, the further the distance traveled. Continuous riding, rather than frequent stopping and starting, will yield the greatest range.

### ⇒ Elevation Gain

Flatter roads allow for greater distance coverage.

### ⇒ Weather

Cold weather can adversely affect battery capacity.

### ⇒ Wind

Riding with a tailwind increases distance traveled, while riding into a headwind decreases it.

### ⇒ Terrain

Smoother terrain (such as roadways) allows for further distance travel compared to rocky trails.

### ⇒ Rider Weight

Lighter riders and loads result in greater distance travel.

### ⇒ Electric Bike Maintenance

Properly maintaining the electric bike ensures optimal range.

### ⇒ Tire Pressure

Properly inflated tires reduce rolling resistance and make pedaling easier.

### ⇒ Batteries

Properly charged and maintained batteries provide the greatest range. Batteries stored in cold areas (below 50°F/10°C) will have reduced range, and batteries not kept in optimal conditions will show diminished range and run time.

## ***Tools Required***

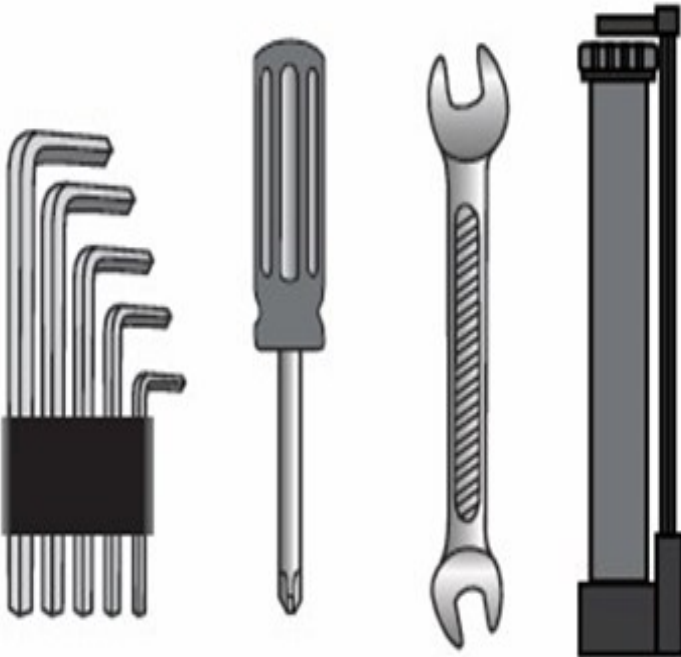

- ⇒ Allen Wrench 2mm,3mm,4mm,5mm,6mm
- ⇒ Philips Head Screwdriver
- ⇒ Wrench
- ⇒ Bicycle Pump

**While performing maintenance on your electric bike as outlined in this manual, please exercise caution when tightening bolts. Improperly tightened components, whether under or over-tightened, may loosen or break, potentially leading to an accident. Additionally, components that fail due to incorrect tightening are not covered under the warranty.**

Your new electric bike was partially assembled at the factory and subsequently partially disassembled for shipping. You may have received your electric bike either fully assembled and ready to ride or in a partially disassembled state within the shipping carton. The following instructions will guide you in preparing your electric bike for years of enjoyable cycling. For comprehensive details on inspection, lubrication, maintenance, and adjustments, refer to the routine maintenance section in this manual. If you have any doubts about your ability to correctly assemble the electric bike, please consult a qualified electric bike service specialist before riding. For replacement parts or any assembly-related inquiries, please contact [Bicycle-Engines.com](http://Bicycle-Engines.com).

# ***Before You Ride***

## **About this manual**

It is crucial for you to acquaint yourself with your new electric bike. By reading this manual before your first ride, you will learn how to enhance the performance, comfort, and enjoyment of your new electric bike. For your safety, your first ride should take place in a controlled environment, away from traffic, obstacles, and other cyclists.

## **General Warning**

Bicycling can be inherently hazardous, even under optimal conditions. Proper maintenance of your electric bike is essential to reduce the risk of injury and is your responsibility. This manual includes "Warnings" and "Cautions" regarding the consequences of inadequate maintenance or inspection. While the terms "serious damage or injury" are used, it is important to note that any fall can result in severe injury or death. Therefore, the warning of possible injury or death may not be reiterated every time a risk is mentioned.

## **A Special Note for Parents**

It is a tragic reality that the majority of bicycle accidents involve children. As a parent or guardian, you are responsible for the safety and activities of your minor child. This responsibility includes ensuring the bicycle is properly fitted to your child, in good repair, and in safe operating condition. Additionally, both you and your child must understand and obey not only the local traffic laws but also the common sense rules of safe and responsible bicycling. As a parent, you should read this manual before allowing your child to ride the bicycle and ensure that your child always wears an ANSI, ASTM, or SNELL approved bicycle helmet while riding.

## **Local Laws**

Before operating this electric bike, it is your responsibility to familiarize yourself with and comply with all applicable local, state, and federal laws and regulations regarding electric bike usage. Laws governing electric bike classifications, speed limits, helmet requirements, permitted riding areas, and other restrictions vary by jurisdiction.

The manufacturer and seller assume no responsibility for fines, penalties, injuries, or damages resulting from improper or unlawful use of this electric bike. Always ride safely, wear appropriate protective gear, and respect traffic laws and regulations.

By using this electric bike, you acknowledge that you have reviewed and understood the legal requirements in your area and accept full responsibility for compliance.

For more information, consult your local transportation authority or government website.

# LCD Display Overview

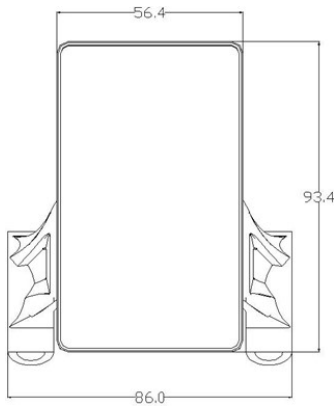

Front View

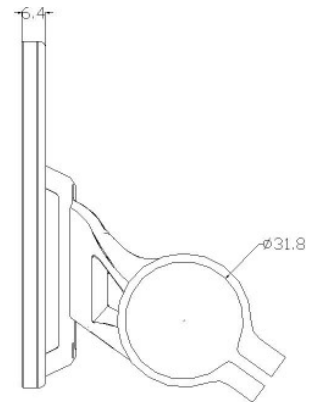

Side View

## LCD Display Specifications:

- ⇒ Working Voltage: DC 24V/36V/48V/60V/72V
- ⇒ Rated Working Current: 12mA
- ⇒ Leakage Current: <1uA
- ⇒ Screen Size: 3.8 Inch LCD
- ⇒ Communication Type: UART (default)/ CAN (Optional)
- ⇒ Optional Functions: Bluetooth, NFC
- ⇒ Working Temperature: -4° F - 140° F
- ⇒ Storage Temperature: -22° F - 158° F
- ⇒ Waterproof Rating: IP65

# LCD Display Operation

## Riding Interface

**Status:** Real-time Riding Status: Bluetooth, Front Light, Brake, Low Voltage, Turning, Cruise, Drive Status, etc.

**Battery Status:** Residual Battery Percentage

**Multi-Function Section:** ODO (total range), TRIP (single rider range), MAX (max. speed), AVG (average speed), TIME (riding time), VOL (battery voltage), Wh (motor power), CUR (current), etc.

**Assist Level Mode:** 3/5/9 Levels available.



## Error Interface

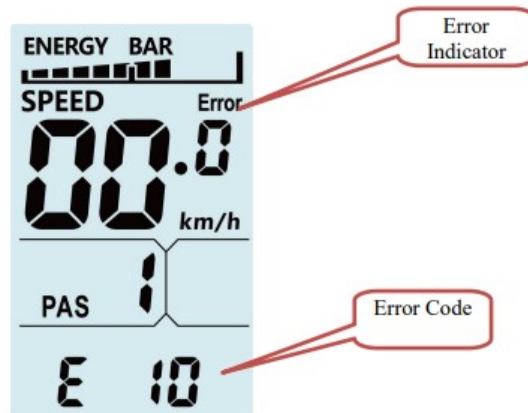

Error Indicator: ERROR, Error Code: E10

## Error Codes

Error Code (decimal)	Status
E00	Normal
E01	Reserved
E02	Brake Error
E03	PAS Sensor Error (Riding Mark)
E04	Walk Assist Mode
E05	Real-Time Cruise
E06	Low Voltage Protection
E07	Motor Error
E08	Throttle Error
E09	Controller Error
E10	Communications Error
E12	BMS Communications Error
E13	Front Light Error

## LCD Display Operation Cont...

### Setting Interface

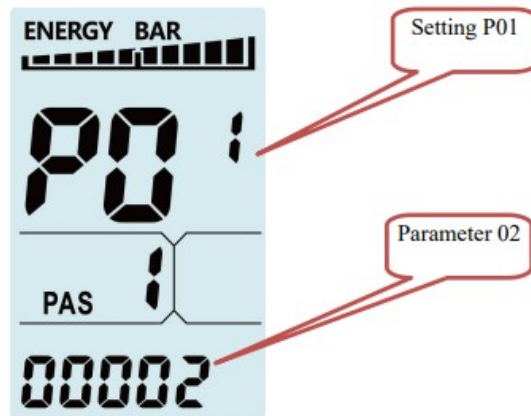

Setting Item: P01, Parameter Value:02

### Setting Codes

**P00:** Factory Reset: optional.

**P01:** Backlight Brightness. 1: darkest; 3: brightest.

**P02:** System Unit. 0: km (metric); 1: mile (imperial).

**P03:** System Voltage: 24V/36V/48V/60V/72V. **Your electric bike is 48V. Be certain it is set correctly.**

**P04:** Auto-Off Time 0: never, other value means auto-off time interval. Unit: minute

**P05:** Pedal Assist Level

0-3 Level Mode; 1-3 Level Mode (no Level0)

0-5 Level Mode; 1-5 Level Mode (no Level0)

0-9 Level Mode; 1-9 Level Mode (no Level0)

**P06:** Wheel Size. Unit: inch; Increment: 0.1.

**P07:** Motor Magnets Number for Speed Gauge. Range: 1-100

**P08:** Speed Limit. Range: 0-60 MPH, communications status(controller-controlled). The max speed will be kept constant at the set value.

**P09:** Direct Start / Kick-to-Start

0: Direct Start (Throttle-on-demand);

1: Kick-to-Start

**P10:** Drive Mode Setting

0: Pedal Assist – The pedal assist level decides the motor power output. In this status the throttle does not work.

1: Electric Drive – The electric bike is only controlled by the throttle. In this status the pedal assist does not work.

2: Pedal Assist + Electric Drive (electric drive does not work in direct-start status)

**P11:** Pedal Assist Sensitivity. Range: 1-24.

**P12:** Pedal Assist Starting Intensity. Range: 0-5.

**P13:** Magnets Number in Pedal Assist Sensor. 3 Types: 5/8/12pcs.

**P14:** Current Limit Value. By default: 12A. Range: 1-20A.

**P15:** Display Low Voltage Value.

**P16:** ODO Clearance. Press and hold the Up key for 5s and ODO value will be cleared.

**P17:** Cruise. 0: cruise function deactivated, 1: cruise function activated.



# ***LCD Display Operation Cont...***

## **Key Operation**

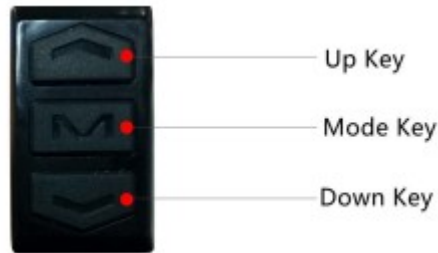

**Press and Hold:** means press and hold the key(s) for more than 2 seconds.

**Press:** means press the key(s) for less than 0.5s.

**Turn on the Display:** When the display is off, press and hold the Mode Key to turn on the display, it will show boot interface and then enter riding interface. (If boot password is activated, enter the boot password at start).

**Turn off the Display:** When the display is on, press and hold the Mode Key, the display will be turned off. If no operation is engaged for 10min(0km/h), the display will auto-off. Auto-off time can be set in the Settings.

**Assist Level:** Press the Up Key or Down Key to switch assist levels. There are 5 levels by default: 0/1/2/3/4/5. 0 means no assist power.

**Toggle Displays:** When the display is on, press the Mode Key to toggle among ODO (Light On/Off total range), Trip (single trip range), TIME (riding time) etc.

**Turn on the Front Light:** When the front light is off, press and hold the Up Key to turn it on, and the light icon will be shown on the riding interface (to remove this function, please reconfigure the controller).

**Turn off the Front Light:** When the front light is on, press and hold the Up Key to turn it off, and the light icon will be off on the riding interface.

**Engage Walk Assist Mode:** On the riding interface, press and hold the Down Key to engage walk assist mode, the walk mode icon will be shown on the riding interface, the real-time speed will be shown in the speed section.

**Disengage Walk Assist Mode:** Release the Down Key to disengage the walk assist mode, the icon will turn off on the riding interface.

# ***Battery Care and Information***

Proper maintenance of batteries will maximize their lifespan and capacity. The manufacturer warranties your new batteries from the date of purchase, provided they are properly cared for—refer to the limited warranty for details.

## **Care**

Although rechargeable batteries have a finite lifespan, proper care can extend their longevity. Each cycle of discharge and recharge slightly reduces the battery's capacity. Follow these instructions to maximize battery life:

### **Recommended Battery Temperature Notes**

Working Temperature:	20°F to 120°F
Charging Temperature:	32°F to 120°F
Storage Temperature:	32°F to 95°F

⇒ Fully charge batteries immediately upon receipt for the full recommended charge time.

**Li-Ion recommended charge time:** 4-6 hours. For a complete charge, leave the battery on the charger for one additional hour after the charger indicator light turns green.

⇒ Never charge batteries for longer than 24 hours.

⇒ Li-Ion batteries do not have a "memory," so partial discharge/charge cycles will not harm capacity or performance.

⇒ The rated output capacity of a battery is measured at 77°F (25°C). Variations in this temperature can affect battery performance and lifespan, with high temperatures particularly reducing overall battery life and run time.

⇒ Always turn the bike power switch to "OFF" after use. Leaving the switch in the "ON" position, or not charging the product for a long period, can cause the batteries to reach a stage where they will no longer hold a charge.

⇒ If the battery will not be used for an extended period, charge it fully and recharge every two months. Store in a cool, dry place.

⇒ Only use the correct charger for the battery and never power other electrical devices with it. Improper use can damage the battery and may cause a fire or explosion. If you hear unusual sounds or smell odors from the battery or charger, discontinue use and unplug immediately. Never operate a damaged battery or charger.

⇒ Do not expose the battery to extreme weather conditions, liquids, fire, or corrosive substances.

⇒ Do not disassemble the battery or charger.

⇒ Be environmentally friendly! Recycle old batteries at a local recycling center—do not throw them in the garbage.

⇒ It is preferable to charge the battery outdoors. If you do charge indoors be sure it's in a well ventilated area away from flammable materials and heat sources to minimize fire risks.

# Battery Care and Information Cont...

## Charging Your Battery

Your Electric Bike Comes With a 48V Charger



Connect the battery first, then plug in the power supply, ensuring the red LED indicator is lit on the charger. A red light indicates that the battery is charging, while a green light shows that the battery is fully charged.



Battery Model - 48V 15.6Ah Lithium Ion



The battery can be charged while it is securely locked in place on your electric bike, or it can be removed and charged independently. The power switch is conveniently located adjacent to the charging port.

The battery includes a charge level display. To view the current charge level, simply press the button.



### Keys

Your electric bike comes equipped with two keys specific to your battery, identifiable by a unique code etched into the lock face. These locks secure the battery in place and deter from theft.

Please note, replacement keys can be expensive, and BicycleEngines.com does not offer replacement keys or cover the cost of replacement. If the keys are lost you will need to contact a locksmith.

# Electric Bike Motor



Your electric bike is equipped with a 48V/500W Brushless Rear Hub Drive Motor.



The motor, motor controller, battery, battery charger, throttle, and wiring harness of your electric bike are not user-serviceable. **DO NOT attempt to disassemble or modify any of these components.** Doing so may result in significant damage, void your warranty, and create a hazardous condition.

- **Maintenance Precaution:** Always remove the battery before performing any maintenance. Conducting maintenance while the drive assist system is active may lead to unintended activation, posing a risk of injury.
- **Cleaning Safety:** Cleaning powered electrical components can cause electric shock, sparks, personal injury, or damage. Always ensure that all electrical components (e.g., battery, display) are powered off and de-energized before cleaning.

For any servicing needs, contact a qualified technician or refer to the manufacturer's guidelines.

## Important Safety Notice

- **Engaging the Drive Assist System:** Always ensure you are seated and have both hands on the handlebars before turning on the drive assist system. Activating the system without full control of the electric bike may result in a loss of control and potential injury.
- **Acceleration and Riding Conditions:** The drive assist system enhances acceleration, making it essential to assess road conditions, sharp turns, and current speed before adjusting assistance levels. Anticipating speed changes and allowing time to react appropriately is crucial for safe operation. Always check your surroundings before accelerating, and reduce the assist level to the lowest setting—or turn it off—when descending hills.
- **Display Connection and Functionality:** The drive assist system requires the display (E-bike computer) to be securely attached to its base. If the display disconnects during a ride, the E-bike may experience unexpected speed changes, including sudden deceleration, which could affect riding stability and nearby traffic. Always be prepared to safely pull over if the display becomes disconnected.

By following these precautions, you can ensure a safer and more controlled riding experience.

# ***Electric Bike Instructions***

## **Getting Started**

Open the carton from the top and carefully remove the electric bike. Remove any straps and protective wrapping from the electric bike. Inspect the electric bike and all accessories and parts to ensure nothing is damaged or missing. It is recommended to lubricate all threads and moving parts in the package before installation. Do not discard packing materials until assembly is complete to ensure no required parts are accidentally discarded. Please note that your bicycle may be equipped with different style components than those illustrated.

## **Battery Installation**

To install the battery, align it with the keyed end facing towards the rear of the bicycle and slide it forward. The teeth on the underside of the battery will engage with the corresponding teeth on the battery mount. Once they click securely into place, the battery is properly mounted.



## **Locking the Battery**

With the battery in place, you can now secure it to the bicycle frame by inserting the key into the battery and turning it. This action will cause a metal cylinder to extend from the base of the battery, locking it firmly to the frame. Once secured, you can remove the key and store it safely until you need to release the battery.



# Electric Bike Instructions Cont...



## Keyed Start

The Beartooth is equipped with a keyed electric power control on the handlebar for added security and safety. To power on, insert and turn the key to the engaged position. The bike will remain powered while the key is in place and will shut off when the key is removed.



## Keys

Your electric bike comes equipped with two keys specific to your bike, identifiable by a unique code etched into the receiver. This keyed mechanism powers the bike and deters from theft.

Please note, replacement keys can be expensive, and Bicycle-Engines.com does not offer replacement keys or cover the cost of replacement. If the keys are lost you will need to contact a locksmith.



## Twist Throttle

Before your ride, turn on the battery power switch and set the keyed power start to the 'on' position. Begin pedaling like a traditional bicycle, then gradually twist the throttle to engage motor assistance. The more you twist, the more power is applied. Fully engaging the throttle allows the motor to reach a maximum speed of 20 mph, making pedaling noticeably easier.



## Horn and Headlight

The handlebars feature quick-access button controls for the headlight and horn. A single press activates the bright, front-mounted headlight for low-visibility conditions, and another press deactivates it. The horn button emits a clear, audible signal to alert others.

# Electric Bike Instructions Cont...

## Stem and Handlebars

### Stem Installation

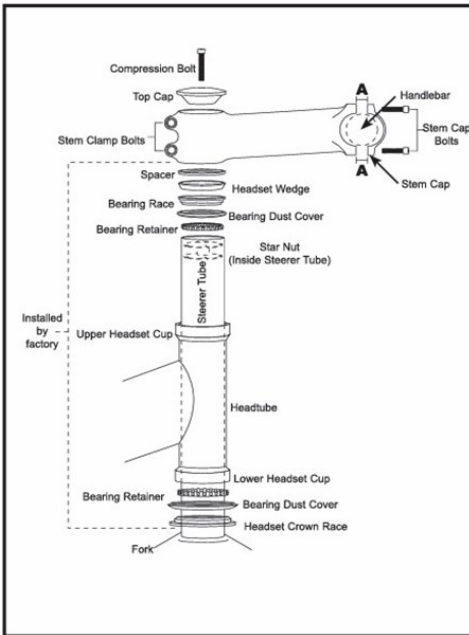

The stem should already come preassembled on your bike.

1. Insert the compression bolt through the top cap and the stem, and begin threading it into the star nut.
2. Tighten the compression bolt to remove all play from the fork, ensuring it rotates smoothly.
3. Align the stem clamp with the front wheel, and tighten the stem clamp bolts to secure the stem to the steer tube.

### Handlebar Installation

1. Remove the stem cap bolts and the stem cap.
2. Insert the handlebar into the stem cap.
3. Tighten the stem cap bolts equally, ensuring the distance between the stem and the stem cap ("A") is equal at the top and bottom of the stem cap.

## Pedal and Crank Set

### Pedal Installation

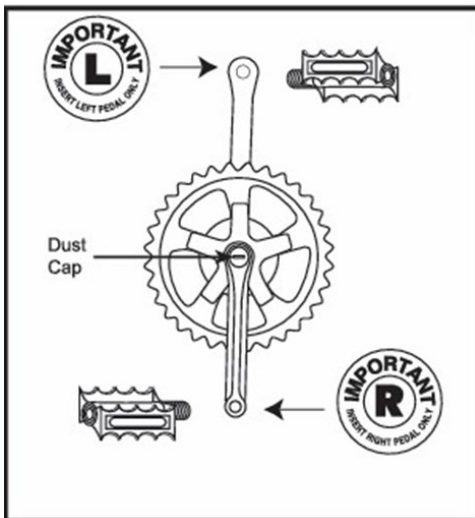

1. Look for the letters "R" (right) and "L" (left) stamped on each pedal spindle. Start threading each pedal by hand to avoid stripping the threads.
2. Tighten the pedals using a narrow open-ended wrench.
3. Note that the right-hand pedal attaches to the chainwheel-side crank arm with a right-hand (clockwise) thread, while the left-hand pedal attaches to the other crank arm with a left-hand (counter-clockwise) thread. It is crucial to check the crank set for correct adjustment and tightness before riding your bicycle. New cranks may become loose with initial use, so check periodically and tighten if needed.
4. Once the pedals are installed, remove the dust caps from the center of each crank arm. Tighten the spindle nuts securely (approximately 350 in. lbs.) with a socket wrench or an Allen wrench, depending on the style.

# Electric Bike Instructions Cont...



## Using Your Gears

Your electric bike is equipped with gears, which change the ratio between the rotations of the rear wheel and the crankset. This allows you to pedal less and travel faster on flat or downhill sections or pedal faster and travel slower to climb hills. Gearing is independent of pedal assistance, so pedal assistance operates the same regardless of the selected gear. However, keep in mind that pedal assistance is governed by overall speed.

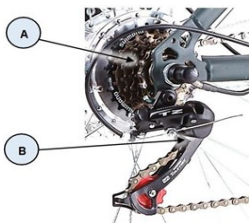

Figure 1

The selectable gears as shown in Figure 1 (A), also known as a "gear cluster" or "cassette," are located on the rear wheel. The larger the gear, the fewer rotations per rotation of the crank. The largest gear is the "lowest" and is referred to as "1." Each subsequent smaller gear is a "higher" gear and is numbered sequentially. Beneath the gear cluster is the derailleur mechanism (Figure 1 (B)), which moves the chain to run on different gears. The derailleur is operated by controls mounted on the handlebars. The gear change is "indexed," ensuring each gear selection positively engages—this is factory set and should require no adjustment.

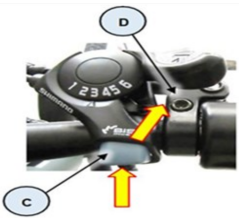

Figure 2

There may be slight variations between bicycle models in the method to change gear "up" (from a lower gear to a higher gear) or to change gear "down" (from a higher gear to a lower gear). The image shows a cassette that uses a button as shown in Figure 2 (C), for changing up gears (push the button to activate the derailleur) and a lever (Figure 2 (D)) for changing down gears (rotate the lever forward to activate the derailleur).

To ensure optimal performance and longevity of your gear system, follow these techniques:

- You **must** be pedaling during gear changes.
- Do not attempt to change multiple gears in a single action. Allow each gear change to complete fully before the next one.
- Always use an appropriate gear for your speed, the terrain, and the incline to ride most efficiently.
- Keep the chain and gears properly lubricated and clean.
- If you hear noise after changing gears, cannot select a gear, or notice the chain not moving smoothly, have the gear system inspected by a qualified professional.



# ***Electric Bike Instructions Cont...***

## **Front Wheel - Bolt-On Installation**

1. Ensure the brakes are loose enough for the wheel to pass through the brake pads easily.
2. Place the wheel into the fork dropouts.
3. Install retaining washers with the raised lip facing the fork, and insert them into the small hole in the fork blade. *Some bikes may have step retaining washers instead. If so, install the step retaining washer, ensuring the raised portion slides into the fork dropouts.*
4. Install the axle nut and tighten it, making sure the wheel is centered between the fork blades.
5. Spin the wheel to ensure it is centered and clears the brake shoes. Adjust the brakes if necessary.

**Note:** It is very important to check the front wheel's connection to the bicycle. Failure to properly tighten may cause the front wheel to dislodge

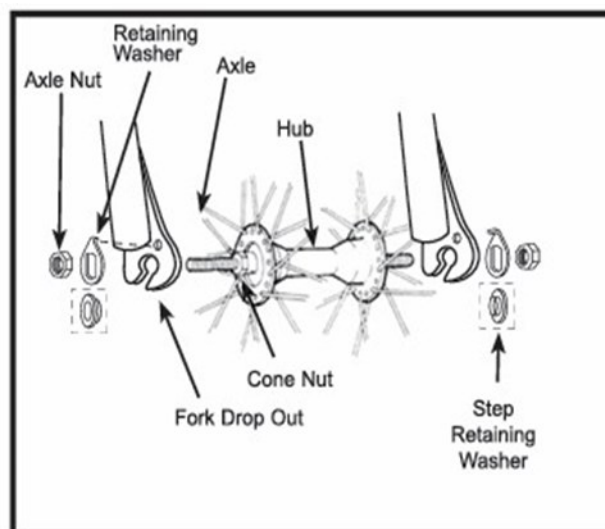

## **Disc Brakes - Shimano**

Disc brakes require a break-in period. Ride and use the brakes gently for about 15 miles before using them in downhill conditions, for sudden stops, or any other serious braking. Be aware that your brake system's performance will change throughout the break-in process. Clean the disc brake before the first ride using rubbing alcohol—never use oil or similar products to clean your disc brake system.

Avoid touching the rotor (disc) with your fingers as much as possible. Oils from your fingers can contaminate the rotor and brake pads, diminishing the brakes' effectiveness. Additionally, brake rotors can get very hot, and severe injury can occur from contact with a hot rotor.

# Electric Bike Instructions Cont...

## Disc Brakes - Shimano Cont...



Figure 1

Ensure the six disc mounting bolts holding the brake rotor onto the wheel are tight. If you need to remove these bolts, use a thread-locking compound when reinstalling them.

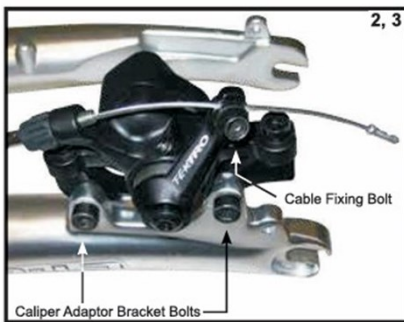

Figure 2,3

(2) Ensure the two bolts securing the caliper adaptor bracket to the fork are tight.

(3) Thread the brake cable through the caliper as shown and secure it with the cable fixing bolt.

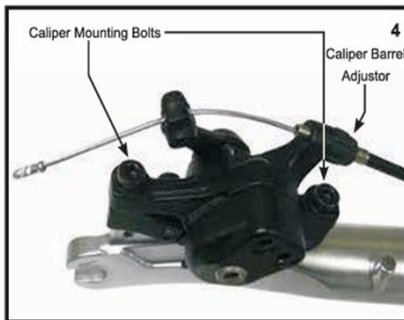

Figure 4

Loosen the two caliper mounting bolts enough to allow the brake caliper to float freely.



Figure 5

Install the wheel, ensuring the brake rotor fits into the caliper slot. Center the caliper around the brake rotor, then tighten the caliper mounting bolts.



Figure 6,7

(6) Using the inner pad adjusting bolt, set the inside brake pad as close to the rotor as possible without causing any rubbing.

(7) Using the caliper barrel adjuster, set the outside brake pad as close to the rotor as possible without causing any rubbing.

# Electric Bike Instructions Cont...

## Derailleur Systems

The derailleur system includes the front and rear derailleurs, the shift levers, and the derailleur control cables, all of which must function correctly for smooth gear shifting.

Although the front and rear derailleurs are initially adjusted at the factory, you will need to inspect and readjust both before riding the bicycle.

## Rear Derailleur Adjustment

1. Shift the rear shifter to the largest number indicated, loosen the cable from the rear derailleur cable anchor bolt, and place the chain on the smallest sprocket.
2. Adjust the high limit screw so the guide pulley and the smallest sprocket are aligned vertically. Retighten the cable, pull out any slack, and securely retighten the anchor bolt.
3. Shift through the gears, ensuring each gear is achieved quietly and without hesitation. If necessary, use the barrel adjuster to fine-tune the cable tension by turning it in the direction you want the chain to go. For example, turning clockwise will loosen the cable tension and move the chain away from the wheel, while turning counterclockwise will tighten the cable tension and direct the chain toward the wheel.
4. Shift the rear shifter to gear one and place the chain on the largest cog. Adjust the low limit screw in quarter-turn increments until the guide pulley and the largest cog are aligned vertically. Again, shift through each gear several times, checking that each gear is achieved smoothly. It may take several attempts to properly adjust the rear derailleur and cable.

**Note:** Ensure all bolts are tightly secured and the chain does not fall off in either direction.

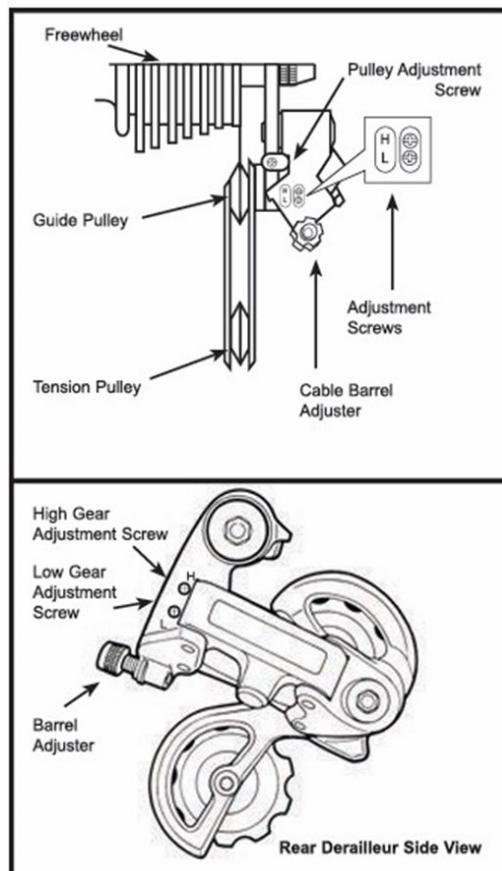

# ***Electric Bike Instructions Cont...***

## **Front Derailleur Adjustment**

1. Shift both shifters to the smallest number indicated and place the chain on the corresponding cog and chainwheel. Disconnect the front derailleur cable from the cable anchor bolt.
2. Check the position of the front derailleur; it should be parallel with the outer chainwheel and clear the largest chainwheel by 1-3mm when fully engaged.
3. With the chain on the smallest chainwheel in front and the largest cog in back, adjust the low limit screw so the chain is centered in the front derailleur cage. Reconnect the cable, pull any slack out, and tighten the anchor bolt securely.
4. Shift the front shifter to the largest chainwheel. If the chain does not engage the largest chainwheel, turn the high limit screw in 1/4 turn increments counterclockwise until the chain engages the largest chainwheel. If the chain falls off the largest chainwheel and into the pedals, turn the high limit screw in 1/4 turn increments clockwise until the chain no longer falls off.
5. Shift through every gear, using the barrel adjusters to fine-tune the cable tension. The barrel adjuster for the front derailleur is located on the front shifter where the cable exits. Turning clockwise will loosen the cable tension and direct the chain closer to the frame, while turning counterclockwise will tighten the cable tension and direct the chain away from the frame.

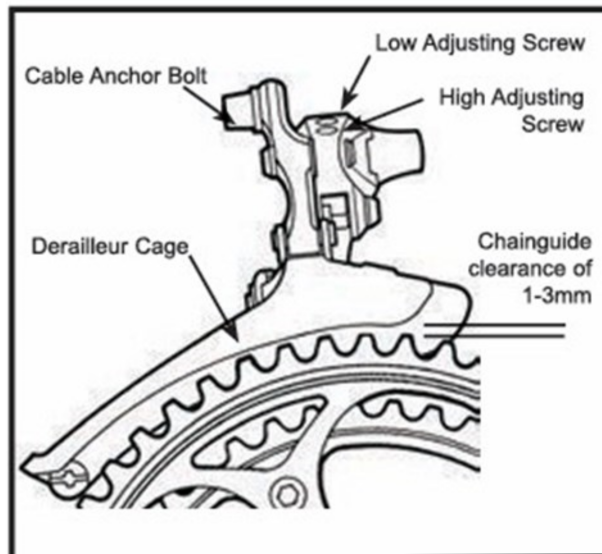

**Note:** Do not ride a bicycle that is not shifting properly. Overlooking proper adjustments may cause irreparable damage to the bicycle and/or cause bodily injury. Never move the shifter while pedaling backwards, nor pedal backwards after moving the shifter, as this could jam the chain and cause serious damage to the bicycle and/or rider.

# ***Safety Checklist***

## **BRAKES**

- ⇒ Ensure both the front and rear brakes function correctly.
- ⇒ Verify that the brake shoe pads are not excessively worn and are correctly aligned with the rims.
- ⇒ Check that the brake control cables are properly lubricated, adjusted, and free from obvious wear.
- ⇒ Ensure the brake control levers are lubricated and securely fastened to the handlebar.

## **WHEELS AND TIRES**

- ⇒ Inflate tires to the recommended pressure as indicated on the tire sidewall.
- ⇒ Confirm that the tires have good tread and show no bulges or excessive wear.
- ⇒ Ensure the rims run true without noticeable wobbles or kinks.
- ⇒ Verify that all wheel spokes are tight and not broken.
- ⇒ Tighten the axle nuts. If equipped with quick-release axles, ensure the locking levers are correctly tensioned and in the closed position.

## **STEERING**

- ⇒ Adjust and tighten the handlebars and stem to allow proper steering.
- ⇒ Align the handlebars correctly with the forks and direction of travel.
- ⇒ Ensure the headset locking mechanism is properly adjusted and tightened.
- ⇒ If the bicycle has handlebar end extensions, ensure they are appropriately positioned and tightened.

## **CHAIN**

- ⇒ Keep the chain oiled, clean, and running smoothly.
- ⇒ Apply extra care in wet or dusty conditions.

## **BEARINGS**

- ⇒ Lubricate all bearings, ensure they run freely, and check for excess movement, grinding, or rattling.
- ⇒ Inspect headset, wheel bearings, pedal bearings, and bottom bracket bearings.

## **CRANKS AND PEDALS**

- ⇒ Securely fasten the pedals to the cranks.
- ⇒ Ensure the cranks are tightly connected to the axle and are not bent.

# ***Safety Checklist Cont...***

## **DERAILLEURS**

- ⇒ Adjust the front and rear derailleurs to function properly.
- ⇒ Attach the shift and brake levers correctly to the handlebar.
- ⇒ Properly lubricate derailleurs, shift levers, and brake cables.

## **FRAME AND FORK**

- ⇒ Inspect the frame and fork for any signs of bending or damage and replace if necessary.

## **ACCESSORIES**

- ⇒ Install all reflectors properly, ensuring they are not obscured.
- ⇒ Securely fasten all fittings on the bike, ensuring proper function.
- ⇒ Ensure the rider is wearing a helmet.

## **MOTOR DRIVE ASSEMBLY AND THROTTLE**

- ⇒ Verify that all motor drive components are correctly mounted and functioning properly.

## **BATTERY PACK**

- ⇒ Maintain the battery in good operating condition and fully charged.

# ***Helmets Save Lives!***

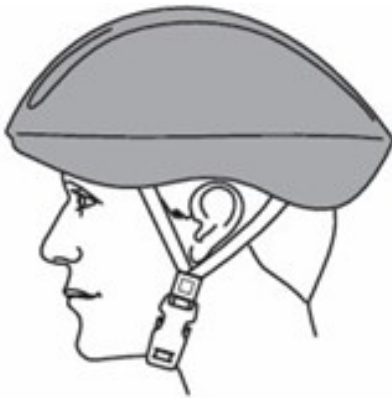

### **PROPER HELMET FITTING**

**The helmet should sit level on your head and low on your forehead— one or two finger-widths above your eyebrow.** Side Straps: Adjust the slider on both straps to form a “V” shape under, and slightly in front of, the ears. Lock the slider if possible.



### **IMPROPER HELMET FITTING**

**The helmet should not be tilted back toward your hairline or at some other jaunty angle.** This is the most common mistake people make with helmet fit.

# ***Final Check and Routine Maintenance***

## **Final Check**

- ⇒ After making all adjustments, shift through each gear several times at varying speeds to ensure the adjustments are correct and to identify any trouble areas. If any issues arise, refer to the appropriate section for necessary adjustments.
- ⇒ Check the tire pressure and inflate each tube to the recommended psi as indicated on the tire sidewall. **NEVER** inflate a tire beyond the maximum pressure listed on the sidewall as it may cause the tire to blow off the rim, leading to damage and injury.
- ⇒ Ensure the kickstand operates smoothly and the kickstand bolt is securely tightened.
- ⇒ Finally, inspect the bicycle to confirm all accessories are attached, and all quick releases, nuts, and bolts are tightly secured. Failure to properly tighten these components can cause damage or injury.
- ⇒ Proper maintenance of your bicycle ensures many years of enjoyable riding. Regularly service your bicycle by referring to the relevant sections of this manual or taking it to a professional bicycle shop.
- ⇒ **Remember:** Always wear a helmet and obey all traffic laws.

## **Routine Maintenance**

Correct routine maintenance of your new bike ensures smooth operation, longer-lasting components, safer riding, and lower running costs.

Every time you ride your electric bike, its condition changes. The more you ride, the more frequent maintenance will be required. We recommend regularly spending a little time on maintenance tasks. If you need assistance, consult a bicycle specialist. Following these schedules is a suggested guideline, but they may vary depending on how often you use the electric bike.

# ***Routine Maintenance Cont...***

## **Lubrication Schedule**

<b>Frequency</b>	<b>Component</b>	<b>Lubricant</b>	<b>How to Lubricate</b>
<b>Weekly</b>	Chain	Chain Lube or Light Oil	Brush On or Squirt
	Derailleur Pulleys	Chain Lube or Light Oil	Brush On or Squirt
	Derailleurs	Oil	Oil Can
	Brake Calipers	Oil	3 drops from oil can
	Brake Levers	Oil	2 drops from oil can
<b>Monthly</b>	Shift Levers	Lithium Based Grease	Disassemble
<b>Every Six Months</b>	Freewheel	Oil	2 squirts from oil can
	Brake Cables	Lithium Based Grease	Disassemble
<b>Yearly</b>	Bottom Bracket	Lithium Based Grease	Disassemble
	Pedals	Lithium Based Grease	Disassemble
	Derailleur Cables	Lithium Based Grease	Disassemble
	Wheel Bearings	Lithium Based Grease	Disassemble
	Headset	Lithium Based Grease	Disassemble
	Seat Post	Lithium Based Grease	Disassemble



# ***Routine Maintenance Cont...***

## **E-Bike Maintenance Schedule**

<b>Frequency</b>	<b>Component</b>	<b>What to Look For</b>	<b>How to</b>
<b>Daily</b>	Tires	Inflated properly, flats, bulges, cuts	Visual Examination, inflate if needed or replace if damaged
	Brakes	Functioning correctly	Squeeze test
	Battery	Charge level	Check indicator on battery if equipped or via bike computer, charge if needed
	Entire Bicycle	Any obvious issues	Quick visual inspection
<b>Weekly</b>	Entire Bicycle	Dirt/Road grime	Clean w/ damp cloth
	Brakes	Wear, alignment, responsiveness	Inspect each component, make adjustments as needed
	Battery	Cleanliness of contacts and connections	Inspect and wipe down contacts and connection points

# ***Routine Maintenance Cont...***

## **E-Bike Maintenance Schedule Cont..**

<b>Frequency</b>	<b>Component</b>	<b>What to Look For</b>	<b>How to</b>
<b>Monthly</b>	Entire Bicycle	Dirt/Road grime	Thorough cleaning, gentle water spray or use bike cleaner and wipe down
	Bolts and Nuts	Loose components, particularly those on handlebars, wheels, and seat	Manual check, use tools or physically check to make sure everything is properly tightened
	Gear System	Gear shifting smoothly	Make adjustments as needed or take to bike shop
	Suspension (if applicable)	Check for proper function	Make adjustments as needed or take to a bike shop

# ***Routine Maintenance Cont...***

## **E-Bike Maintenance Schedule Cont...**

<b>Frequency</b>	<b>Component</b>	<b>What to Look For</b>	<b>How to</b>
<b>Quarterly/Yearly</b>	Tires	Wear and tear	Replace if too worn down
	Brakes	Proper function and check for wear and tear on all braking components	Inspect entire braking system, replace and worn out parts including frayed cables
	Battery	Check battery and components for cleanliness and health	If battery health has declined consider replacing, clean components
	Frame	Cracks or other damage	Clean and inspect frame, repair or replace damaged parts or have serviced
	Bearings	Check wheel and pedal bearings	Lubricate or replace where needed
	Motor	Unusual noises or performance issues	Have serviced by professional

# ***Troubleshooting***

<b>Problem</b>	<b>Possible Cause</b>	<b>Remedy</b>
<b>Gears not working properly</b>	<p>Derailleur cables sticking/stretched/damaged</p> <p>Front or rear derailleur not adjusted properly</p> <p>Indexed shifting not adjusted properly</p>	<p>Lubricate/tighten/replace cables</p> <p>Adjust derailleurs</p> <p>Adjust indexing</p>
<b>Slipping Chain</b>	<p>Excessively worn/chipped chainring or freewheel sprocket teeth</p> <p>Chain worn/stretched</p> <p>Stiff link in chain</p> <p>Non-compatible chain/chainring/ freewheel</p>	<p>Replace chainring, sprockets and chain</p> <p>Replace chain</p> <p>Lubricate or replace link</p> <p>Seek advice at a bicycle shop</p>
<b>Chain jumping off freewheel sprocket or chainring</b>	<p>Chainring out of true</p> <p>Chainring loose</p> <p>Chainring teeth bent or broken</p> <p>Rear or front derailleur side to-side travel out of adjustment</p>	<p>Re-true if possible, or replace</p> <p>Tighten mounting bolts</p> <p>Repair or replace chainring/set</p> <p>Adjust derailleur travel</p>
<b>Constant clicking noises when pedaling</b>	<p>Stiff chain link</p> <p>Loose pedal axle/bearings</p> <p>Loose bottom bracket axle/bearings</p> <p>Bent bottom bracket or pedal Axle</p> <p>Loose Crankset</p>	<p>Lubricate chain / Adjust chain link</p> <p>Adjust bearings/axle nut</p> <p>Adjust bottom bracket</p> <p>Replace bottom bracket axle or pedals</p> <p>Tighten crank bolts</p>

## ***Troubleshooting Cont...***

<b>Problem</b>	<b>Possible Cause</b>	<b>Remedy</b>
<b>Constant clicking noises when pedaling</b>	Stiff chain link	Lubricate chain / Adjust chain link
	Loose pedal axle/bearings	Adjust bearings/axle nut
	Loose bottom bracket axle/bearings	Adjust bottom bracket
	Bent bottom bracket or pedal axle	Replace bottom bracket axle or pedals
	Loose crankset	Tighten crank bolts
<b>Grinding noise when pedaling</b>	Pedal bearings too tight	Adjust bearings
	Bottom bracket bearings too tight	Adjust bearings
	Chain fouling derailleurs	Adjust chain line
	Derailleur jockey wheels dirty	Clean and lubricate jockey wheels
<b>Freewheel does not rotate</b>	Freewheel internal pawl pins are jammed	Lubricate. If problem persists, replace freewheel
<b>Brakes not working effectively</b>	Brake blocks worn down	Replace brake blocks
	Brake blocks/rim greasy, wet or dirty	Clean blocks and rim
	Brake cables are binding/stretching/damaged	Clean/adjust/replace cables
	Brake levers are binding	Adjust brake levers
	Brakes out of adjustment	Center Brakes
<b>When applying the brakes they squeal/squeak</b>	Brake blocks worn down	Replace blocks
	Brake block toe-in incorrect	Correct block toe-in
	Brake blocks/rims dirty or wet	Clean blocks and rim
	Brake arms loose	Tighten mounting bolts

## ***Troubleshooting Cont...***

<b>Problem</b>	<b>Possible Cause</b>	<b>Remedy</b>
<b>When applying the brakes they squeal/squeak</b>	Brake blocks worn down Brake block toe-in incorrect Brake blocks/rims dirty or wet Brake arms loose	Replace blocks Correct block toe-in Clean blocks and rim Tighten mounting bolts
<b>Knocking or shuddering when applying brakes</b>	Bulge in the rim or rim out of true Brake mounting bolts loose Brakes out of adjustment Fork loose in head tube	True wheel or take to bike shop for repair Tighten bolts Center brakes and/or adjust brake block toe-in Tighten headset
<b>Wobbling wheel</b>	Axle broken Wheel out of true Hub comes loose Headset binding Hub bearings collapsed QR mechanism loose	Replace axle True wheel Adjust hub bearings Adjust headset Replace bearings Adjust QR mechanism
<b>Steering not accurate</b>	Wheels not aligned in frame Headset loose or binding Front forks or frame bent	Align wheels correctly Adjust/tighten headset Take bike to bike shop for possible frame realignment
<b>Frequent tire punctures</b>	Inner tube old or faulty Tire tread/casing worn Tire unsuited to rim Tire not checked after previous puncture Tire pressure too low Spoke protruding into rim	Replace inner tube Replace tire Replace with correct tire Remove sharp object embedded in tire Correct tire pressure File down spoke

***This  
Page  
Intentionally  
Left  
Blank***